

Towards a benchmark simulation model for plant-wide control strategy performance evaluation of WWTPs

U. Jeppsson*, C. Rosen*, J. Alex**, J. Copp***, K.V. Gernaey****, M.-N. Pons*****
and P.A. Vanrolleghem*****

*Department of Industrial Electrical Engineering and Automation, Lund University, Box 118, SE-221 00 Lund, Sweden (E-mail: ulf.jeppsson@iea.lth.se, christian.rosen@iea.lth.se, krist.gernaey@iea.lth.se)

**IFAK System GmbH, Oststrasse 18, D-39114 Magdeburg, Germany (E-mail: ali@ifak-md.de)

***Hydromantis, Inc., 1685 Main St. West, Hamilton, Ontario L8S 1G5, Canada (E-mail: copp@hydromantis.com)

****Department of Chemical Engineering, Technical University of Denmark, DK-2800 Kgs. Lyngby, Denmark (E-mail: kvg@kt.dtu.dk)

*****LSGC-CNRS-ENSIC-INPL, 1 rue Grandville, BP 451, F-54001 Nancy cedex, France (E-mail: marie-noelle.pons@ensic.inpl-nancy.fr)

*****BIOMATH, Ghent University, Coupure Links 653, B-9000 Ghent, Belgium (E-mail: peter.vanrolleghem@ugent.be)

Abstract The COST/IWA benchmark simulation model has been available for seven years. Its primary purpose has been to create a platform for control strategy benchmarking of activated sludge processes. The fact that the benchmark has resulted in more than 100 publications, not only in Europe but also worldwide, demonstrates the interest in such a tool within the research community. In this paper, an extension of the benchmark simulation model no 1 (BSM1) is proposed. This extension aims at facilitating control strategy development and performance evaluation at a plant-wide level and, consequently, includes both pre-treatment of wastewater as well as the processes describing sludge treatment. The motivation for the extension is the increasing interest and need to operate and control wastewater treatment systems not only at an individual process level but also on a plant-wide basis. To facilitate the changes, the evaluation period has been extended to one year. A prolonged evaluation period allows for long-term control strategies to be assessed and enables the use of control handles that cannot be evaluated in a realistic fashion in the one-week BSM1 evaluation period. In the paper, the extended plant layout is proposed and the new suggested process models are described briefly. Models for influent file design, the benchmarking procedure and the evaluation criteria are also discussed. And finally, some important remaining topics, for which consensus is required, are identified.

Keywords Benchmark; BSM1; BSM2; control; modelling; simulation; wastewater treatment

Introduction

The use of a benchmark for assessment of process performance, control system evaluation, etc. is well established within chemical engineering and research. An example of this is the Kodak Tennessee Eastman Process (Downs and Vogel, 1993). The success of the COST/IWA benchmark (e.g. Copp, 2002; Jeppsson and Pons, 2004; Spanjers *et al.*, 1998) for control strategy development and evaluation clearly indicates the usefulness of such a tool for the wastewater research community. More than 100 reports on work related to the benchmark have, at the time of writing this paper, been published. The simulation model is used by numerous research groups around the world for various purposes and is available as a predefined software tool in several commercial wastewater treatment plant (WWTP) simulator packages (e.g. GPS-X™, SIMBA®, WEST®).

The main efforts towards the development of the benchmark have been carried out within the IWA Task Group on Respirometry and COST Actions 682 and 624. Although these groups are no longer formally active, the core group of benchmark developers have decided to continue their collaboration and seek out new avenues for co-operation. The reason for such an effort is an identified need for further improvements to benchmark systems for WWTPs. A tentative benchmark system focussing on long-term control and monitoring performance evaluation (BSM1_LT) has already been proposed (Rosen *et al.*, 2004). In this paper, the concepts for plant-wide, long-term control performance evaluation are given.

The benchmark simulation model no. 1 (BSM1) definition, in short, consists of the model, an associated control system, a benchmarking procedure and an evaluation criteria. The model is a five-reactor activated sludge plant configuration with a (non-reactive) secondary clarifier, utilising the activated sludge model no. 1 (ASM1) for modelling of the biological reactions (Henze *et al.*, 1987) and a ten-layer Takács model describing the clarifier (Takács *et al.*, 1991). Model parameter values and files characterising the influent wastewater are also provided. Although considerable flexibility is provided so as not to limit the creativity of the user-defined control strategy to be tested, only specified control handles and sensors are to be used. The benchmarking procedure is a step-wise protocol that includes implementation, initialisation and evaluation of control system performance using a predefined one-week evaluation period. The evaluation is carried out according to a number of specified criteria (e.g. effluent quality, operational cost, sludge production, energy usage and number/magnitude of effluent violations).

Although a valuable tool, the basic BSM1 does not allow for evaluation of control strategies on a plant-wide basis. BSM1 includes only an activated sludge system and a secondary clarifier. Consequently, only local control strategies can be evaluated. During the last decade the importance of integrated and plant-wide control has been stressed by the research community and the wastewater industry is starting to realise the benefits of such an approach. A WWTP should be considered as a unit, where primary/secondary clarification units, activated sludge reactors, anaerobic digesters, thickeners, dewatering systems, etc. are linked together and need to be operated and controlled not only on a local level as individual processes but by supervisory systems taking into account all the interactions between the processes. Otherwise, sub-optimisation will be an unavoidable outcome leading to reduced effluent quality and/or higher operational costs.

It is the intent of the proposed extended benchmark systems to take the issues stated above into account. Consequently, wastewater pre-treatment and the sludge train of the WWTP are included. To allow for more thorough evaluation and additional control handles operating on longer time-scales, the benchmark evaluation period is extended to one year (compared to one week in BSM1). The slow dynamics of anaerobic digestion processes also necessitate a prolonged evaluation period. With this extended evaluation period, it is reasonable to include seasonal effects on the WWTP in terms of temperature variations. The data files describing the BSM1 influent wastewater (dry, storm and rain weather data) have been used extensively by researchers. However, for the extended benchmark system an attempt will be made to create mathematical models for raw wastewater and storm water generation, including urban drainage and sewer system effects. Additionally, intermittent loads reaching the plant by other means of transportation (e.g. trucks) will be included. Such input data generation models serve an additional research need beyond the scope of the benchmark system. A final goal of the work is to combine the ideas of BSM1_LT (monitoring, process disturbances, sensor failures, etc.) with the benchmark system discussed in this paper (plant-wide aspects) into a single model.

In this paper, we discuss aspects of a possible plant-wide model definition for control strategy development and performance evaluation including benchmarking procedures and evaluation criteria. It should be stressed that this is a proposal and not a final definition. It is our hope that this paper will initiate discussion within the scientific community, so that consensus can be reached on a plant-wide evaluation tool, i.e. the benchmark simulation model no. 2 (BSM2).

BSM2 model definition

In this section, we identify issues that need to be addressed and propose some ideas for the final definition of the BSM2. It is our intention to include as many features of BSM1 as possible in terms of process layout, volumes, process models, etc. although because the influent wastewater will be somewhat different (i.e. the characteristics, temperature effects and new recycle streams will change the character of the influent), the activated sludge process behaviour will not be identical. The principles and ideas from BSM1_LT are included when possible. The main focus of this paper is related to the plant layout and the process definitions but control handles, sensors and influent wastewater characteristics are also discussed.

Process definition

It cannot be stressed enough that the purpose of the benchmark is the development of a tool that can be used to evaluate the performance of proposed control strategies rather than simulate the detailed behaviour of a real WWTP. Consequently, the benchmark is not defined by any national standards or design principles but aims at describing a general plant and the main processes that may be found at WWTPs in most industrialised countries.

Plant layout. The proposed layout for the BSM2 WWTP is shown in Figure 1. The activated sludge reactors and secondary clarifier are identical to the ones used in BSM1 and will not be further discussed. The pumps and valves indicate control handles on a plant-wide level, but more control options are available within the different processes.

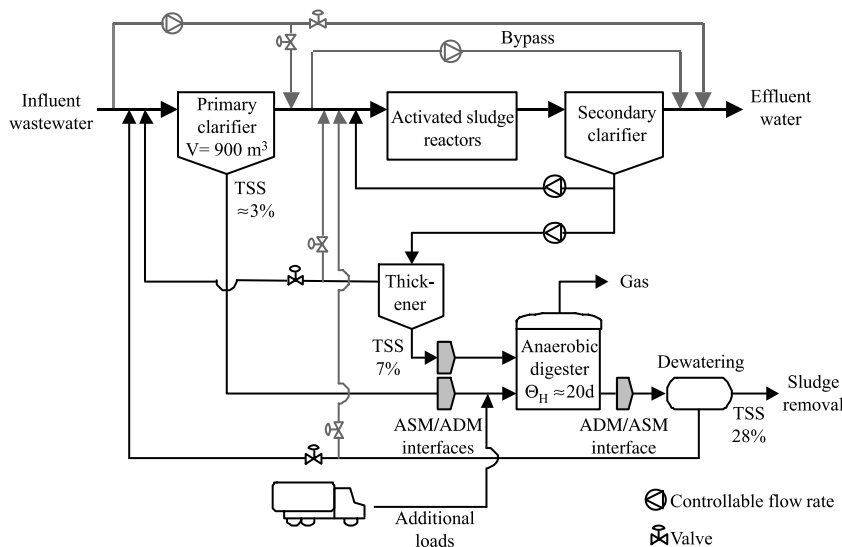

Figure 1 Plant layout for the proposed BSM2

Proposed concentrations of total suspended solids (TSS) in certain underflows and in the dewatered sludge are indicated.

Primary clarifier. The proposed primary clarifier is modelled according to Otterpohl and Freund (1992) and Otterpohl *et al.* (1994). It is described as one completely mixed tank with separation of the effluent into a water stream and a sludge stream. The incoming solids are concentrated into the sludge stream based on an empirical expression taking into account the hydraulic retention time and ratio of particulate to total COD. The model parameters are defined to produce a TSS concentration in the sludge stream equal to 3% for the average dry weather influent wastewater and a TSS removal efficiency of 50%. During dynamic conditions the primary sludge flow rate is set to be proportional to the influent flow rate and the concentrations of particulate components are allowed to vary. The concentrations of soluble components are not affected and are equal in both outward streams (taking into consideration dilution and the liquid volume of the clarifier). The clarifier is assumed to be 3 m deep with a cross-sectional area of 300 m². This is equivalent to a hydraulic retention time of approximately 1.2 hours for the average dry weather influent flow rate. No biological reactions are assumed to occur within the primary clarifier. Sludge hydrolysis, therefore, is neglected. This is consistent with the BSM1 secondary clarifier, which is also assumed to be biologically inactive. However, validation of reactive settler models is currently being carried out among the benchmark developers (Gernaey *et al.*, 2005). TSS is calculated as in BSM1.

Thickener unit. The wastage flow from the secondary clarifier is fed to the thickener. BSM2 (as was the case in BSM1) does not take into account changing sludge characteristics but rather assumes sludge with good settling qualities. In accordance with this simplification the thickener is modelled as an ideal, continuous process with no biological activity. 98% of all particulate matter entering the thickener unit is assumed to settle and end up in the thickened sludge stream. The concentrations of soluble components are equal in both outward streams (identical to the influent concentrations). During dynamic conditions the underflow TSS concentration (7%) is maintained through instantaneous flow rate adjustments. TSS is calculated as in BSM1.

Anaerobic digester. Anaerobic digestion model no. 1 (ADM1) by Batstone *et al.* (2002) is a published and recognised dynamic anaerobic digestion model. Consequently, ADM1 was chosen as the anaerobic digestion model for BSM2. The model includes the biological reactions in the water phase as well as the liquid–gas interactions and gas production. Some modifications to the original ADM1 model are proposed for BSM2 (in terms of inhibition functions, gas flow calculation, etc.) but the details of these changes are outside the scope of this paper. The proposed digester is a mesophilic reactor (35°C) with a retention time of approximately 20 days (constant liquid volume and gas volume 10% of liquid volume). Exact values will be defined by steady-state simulations of BSM2 using the average dry weather influent wastewater. Although the digester behaviour is stable (unless the process collapses) and the digester size dampens many of the faster dynamics, it is essential for the plant-wide behaviour to correctly model the reactions so that sludge production and the content of return liquors from sludge treatment are described adequately. Energy consumption will be associated with the operation of the digester (for heating and mixing purposes) and gas production (methane) will be monitored for proper evaluation of the benchmark system. Although primarily based on COD and nitrogen balances (as ASM1), many of the state variables are different from those used by the rest of the BSM2 system. Therefore, model interfaces

are included (see below). The AD model has already been verified and validated by the benchmark group using several independent implementations using different software platforms.

Dewatering unit. Efficient dewatering is essential for overall plant performance and must be included. However, as it is typically a mechanical process (several types of equipment based on somewhat different principles are available), it is modelled as an ideal, continuous process with no biological activity. 98% of all particulate matter entering the dewatering unit is assumed to be concentrated into the sludge stream and subsequently removed. The concentrations of soluble components are equal in both outward streams (identical to the influent concentrations). During dynamic conditions the TSS concentration (28%) is maintained through instantaneous flow rate adjustments. Energy consumption (based on a centrifuge system) will be associated with the dewatering process. TSS is calculated as in BSM1.

Model interfaces. As the state variables used in the AS and AD models are quite different, model interfaces are necessary when combining the two processes. A rudimentary interface is proposed in [Batstone *et al.* \(2002\)](#). However, the benchmark developers have created a more elaborate version. The proposed interfaces between ASM1 and ADM1 are described in detail in [Copp *et al.* \(2003\)](#). The ASM1/ADM1 interface basically removes any oxygen and nitrate in the wastewater with an associated COD reduction and then divides the remaining COD and nitrogen components into relevant ADM1 state variables (e.g. proteins, lipids, carbohydrates). As primary and secondary sludges differ, the parameters defining the interfaces are somewhat different for the two streams, but the conversion principles are the same. No inputs entering the digester will be defined as composite material (a special state variable of ADM1 describing a general mix of components) and therefore the disintegration process of ADM1 will only influence the behaviour of the model in terms of internal disintegration of products arising from biomass decay. The interface model describes disintegration of influent sludge (not included in [Copp *et al.*, 2003](#)). The ADM1/ASM1 interface amalgamates the large number of ADM1 state variables back into the ASM1 state variables. At all times, COD and nitrogen mass balances are maintained. Work is also on-going to develop more general structures for interfacing models based on the Petersen matrix description ([Vanrolleghem *et al.*, 2004](#)).

Influent wastewater generation

The BSM1 influent is defined by data files describing the influent wastewater for dry, storm and rain weather conditions. For BSM2, the influent wastewater characteristics are still to be decided. However, there is a general agreement that the BSM2 influent should be based on a model rather than pre-defined data files. The influent model will include the typical phenomena that are typically observed in a year of full-scale WWTP influent data. For dry weather, the model will include: (1) diurnal phenomena, which can be modelled using a second-order harmonic function; (2) a lower average flow rate and pollutant concentration during weekends compared to normal week days, in an attempt to simulate a WWTP that receives a mixed municipal–industrial wastewater; (3) seasonal phenomena reflecting typical effects from the sewer system and urban drainage, i.e. increased infiltration in winter related to higher groundwater levels; (4) holiday periods during which time a lower average wastewater flow rate is maintained over a period of several weeks.

The dry weather model will furthermore be combined with rain and storm weather generation, to account for ‘first flush’ effects from the sewer network and dilution phenomena that are typically observed at full-scale WWTPs. In addition to flow rate and ASM1 model state variables, the influent model will include wastewater temperature for describing seasonal temperature variations. Finally, BSM2 will contain a model generating concentrated biosolid waste defined by ADM1 state variables in an attempt to mimic the arrival of truckloads of concentrated waste flows (e.g. septic tank waste) to the digester. The primary reason for this intermittent input is to create more dynamic disturbances in the digester and thereby be an incentive for control. An alternative would be to add such an input to the primary clarifier but then the dynamic impact on the digester would be limited due to the smoothing effects of the clarifier.

Additional control handles

The plant-wide description as well as the long-term vision of BSM2 allow for more control handles than those of BSM1. Wastage flow rate is a control handle in BSM1, but it does not result in a stable effect within a week. However, an evaluation period of a year makes sludge retention time (SRT) control possible. Due to the static hydraulic modelling of the primary clarifier, thickener and dewatering unit, the streams in the sludge train are exclusively determined by the influent flow rate and the wastage flow rate (unless extra storage tanks and associated pumps are introduced). However, it is possible to control the destination of the sludge train recycle streams. Another control handle is bypassing: bypassing from the influent to the activated sludge system and/or to the plant effluent and bypassing from the primary clarifier effluent to the plant effluent. Other control handles are also possible including equalisation and sludge storage tanks (not shown in [Figure 1](#)).

Sensor modelling

It is well established that sensors have dynamic properties. Sensor signals are subject to noise, drift is commonly observed and sensors need to be calibrated and maintained periodically. To emulate such sensor behaviour and test the control scheme for its sensitivity to this is crucial. Realistic sensor model behaviour requires that the dynamic properties and disturbance sources are represented. This includes modelling of noise, time response, drift, signal saturation and, if not a continuous sensor, the measuring interval. Sensor models as described by [Rieger *et al.* \(2003\)](#), are now a part of the BSM1 definition and the same models are proposed for BSM2 and BSM1_LT.

Temperature trajectory and dependencies

It is known that seasonal effects can have a significant impact on the operation of a treatment plant. An important reason for this is temperature variation. As the evaluation period spans one year, temperature will be a necessary factor. A common trajectory for the temperature over a year is more or less sinusoidal with its maximum value in mid-summer and its minimum value in mid-winter. Although the wastewater temperature is affected by more complex phenomena such as precipitation and snow melting, it was reasoned that a sinusoidal temperature trajectory would suffice as an approximation. The temperature is modelled as $T = 15 + 5 \cdot \cos(2\pi/365(t - 28))^\circ\text{C}$, where t is the day of the year and the shift is 28 days. As a result, the values of the temperature-dependent kinetic parameters in the ASM1 model will vary during the evaluation period. In [Henze *et al.* \(1987\)](#), kinetic parameter values are given for 10 and 20°C, and intermediate values can be calculated according to an Arrhenius function. Although temperature has an effect on basically all processes in a treatment plant, only the activated sludge process is influenced by temperature in BSM2. Changing settling and dewatering characteristics of the sludge

are not included. Moreover, to avoid including complete energy balances in all process models the influent wastewater temperature is considered to be the actual temperature in all reactors (except in the mesophilic digester).

BSM2 benchmarking procedure

The benchmarking procedure includes the implementation of the control system, initialisation of the model, simulation of the one-year scenario and evaluation of the system performance in terms of effluent quality and operational costs. We will in this section discuss what the procedures for plant-wide control benchmarking could look like and describe how BSM2 can be used for objective evaluation of different control strategies.

Implementation

The benchmark user carries out the implementation of a control system, possibly into verified implementations of the BSM2 plant available in commercial simulation platforms. Issues such as choice of sensors, control handles and sampling time are resolved by the user utilising what is available and allowed within the benchmark definition. If deviations from the model definition are implemented (e.g. operating ranges for actuators or sensors not defined in the model descriptions) these must be fully documented to allow for reproduction of results. It is the user's responsibility to ensure that the model is correctly implemented and verified according to the BSM2 specifications.

Initialisation

In BSM1, the initialisation consists of simulating the benchmark, with the control strategy that is to be evaluated, for 100 days with constant input, followed by three weeks of dry weather dynamic input data. This is done to obtain a pseudo-steady-state and to allow for the fair comparison of various strategies. The initialisation period for BSM2 must be prolonged because of the slow dynamics related to the interconnections in the plant and the anaerobic digester. Moreover, control strategies acting over long time scales need a long initialisation phase. This is also the case for BSM1_LT mentioned earlier. It is desirable that the initialisation and simulation procedure for BSM2 be the same as the procedure for BSM1_LT. The preliminary definition of BSM1_LT suggests a steady-state initialisation period of 200 days (using the mean values of the influent concentrations and flow rate of the first week in January) followed by a six-month dynamic initialisation period with the control strategies under study active. The states of the system at the end of the initialisation period are then used as the starting point for the dynamic evaluation.

Simulation

In contrast to BSM1, where separate files for dry, rain and storm weather conditions are provided, various conditions are included in the model for creating influent data for the evaluation period. The beginning and end of the evaluation period is summer in an attempt to minimise the risk that negative effects of a proposed control strategy are pushed beyond the end of the evaluation period. Output data should be recorded at 15-minute intervals. This may seem to be a high sampling rate on a yearly basis but having the same sampling rate as in BSM1 simplifies the comparison between the benchmark platforms. An extensive storage of variables and states will not exceed 100 MB storage space, which is considered acceptable for a modern computer. The whole period is used to calculate key variables and assess the performance using the defined evaluation criteria.

Evaluation of system performance

To assess the performance of the plant and control strategy, evaluation criteria are necessary. These criteria aim at condensing the simulation output into a few indices or key variables that represent the system and controller performance, which should simplify the comparison of results. In BSM1, the system performance is evaluated according to an effluent quality index (a weighted sum of effluent TSS, COD, BOD, TKN and nitrate), effluent violations (frequency and magnitude) and operational costs (pump energy, aeration energy, sludge disposal and external carbon source). Also, the controller performance is assessed in terms of controlled variable performance and manipulated variable performance (Copp, 2002). We can see no reason for changing this definition when using BSM2 for plant-wide control benchmarking. However, in the operational cost index, the sludge treatment cost term is specified further into heating energy, sludge dewatering and landfill costs. Also, although the gas production most likely will be a key variable by itself, it should also be included in the operational cost index as a negative cost.

Conclusions

Over the past two years, the idea has grown to extend the successful IWA/COST BSM1 by including a primary clarifier and a sludge treatment train. This has resulted in a plant-wide or “within-fence” benchmark model that has been termed BSM2. In this paper, a first complete definition of BSM2 is proposed. Process models and designs were made for the primary clarifier (Otterpohl model), the secondary sludge thickener (ideal separator), the mesophilic anaerobic digester (IWA’s ADM1) and sludge dewatering (ideal separator). Bypass and return flows were identified. To increase the dynamics of the system an additional source of wastes into the plant was added by assuming that truckloads of wastes (sludge, organic wastes, etc.) were added directly to the anaerobic digester for treatment. An important issue is also the definition of transformers between the ASM1 and the ADM1.

The evaluation of control systems acting on long-term time scales (e.g. SRT control) necessitates influent trajectories that span a complete year and new evaluation criteria that also encompass the inputs and outputs of the sludge treatment train. Important remaining elements for which consensus needs to be sought concern the definition of the one-year influent trajectories/models, evaluation criteria and a set of available sensors and actuators. Overall evaluation of the BSM2 plant configuration as proposed in this paper can also be expected to lead to slight modifications.

Important in view of the development of BSM2, is that the work can take advantage of synergies with the development of another benchmark defined around the original activated sludge system, but focusing on the evaluation of process monitoring methods (Rosen *et al.*, 2004). Also in that benchmark, long-term evaluation is essential and, hence, it was termed long-term BSM1, BSM1_LT. Extensive reuse of elements common to both BSM1_LT and BSM2 is being pursued and should enhance the development progress. In the next few years it can be expected that these two new BSMs lead to new insights into long-term performance of controlled activated sludge systems, including sludge treatment and process monitoring systems.

Acknowledgements

The authors wish to thank the European COST Programme. The paper is the outcome of fruitful discussions during a COST Action 624 Working Group No. 1 meeting in Lund, Sweden in December 2003, including (apart from the authors): E. Ayesa, D. Batstone, P. Ingildsen, N. Hvala, B. Klapwijk, G. Olsson, D. Vrecko and S. Winkler. Many more have contributed to the benchmark development over the years and the authors wish to

express their sincere gratitude to all. Peter Vanrolleghem also wishes to thank the Fund for Scientific Research for the financial support during his sabbatical leave at Lund University.

References

- Batstone, D.J., Keller, J., Angelidaki, I., Kalyuzhnyi, S.V., Pavlostathis, S.G., Rozzi, A., Sanders, W.T.M., Siegrist, H. and Vavilin, V.A. (2002). *Anaerobic Digestion Model No. 1*. IWA STR No. 13, IWA Publishing, London, UK.
- Copp, J.B. (ed.) (2002). The COST Simulation Benchmark. In *Description and Simulator Manual*. Office for Official Publications of the European Communities, Luxembourg.
- Copp, J.B., Jeppsson, U. and Rosen, C. (2003). Towards an ASM1–ADM1 state variable interface for plant-wide wastewater treatment modeling. In *Water Environment Federation Conference, WEFTEC 2003*, Los Angeles, California, USA, 11–15 October 2003.
- Downs, J.J. and Vogel, E.F. (1993). A plant-wide industrial-process control problem. *Comp. Chem. Eng.*, **17**(3), 245–255.
- Gernaey, K.V., Jeppsson, U., Batstone, D.J. and Ingildsen, P. (2005). Impact of reactive settler models on simulated WWTP performance. *Wat. Sci. Tech.*, **53**(1), 159–167 (this issue).
- Henze, H., Grady, C.P.L., Jr, Gujer, W., Marais, G.v.R. and Matsuo, T. (1987). *Activated Sludge Model No. 1*, IWA Publishing, London, UK.
- Jeppsson, U. and Pons, M.-N. (2004). The COST 624 benchmark simulation model – current state and future perspective (Editorial). *Control Engineering Practice*, **12**(3), 299–304.
- Otterpohl, R. and Freund, M. (1992). Dynamic models for clarifiers of activated sludge plants with dry and wet weather flows. *Wat. Sci. Tech.*, **26**(5–6), 1391–1400.
- Otterpohl, R., Raak, M. and Rolfs, T. (1994). A mathematical model for the efficiency of the primary clarification. Presented at *IAWQ 17th Biennial International Conference*, Budapest, Hungary, 24–29 July 1994.
- Rieger, L., Alex, J., Winkler, S., Boehler, M., Thomann, M. and Siegrist, H. (2003). Progress in sensor technology – progress in process control? Part I: Sensor property investigation and classification. *Wat. Sci. Tech.*, **47**(2), 103–112.
- Rosen, C., Jeppsson, U. and Vanrolleghem, P.A. (2004). Towards a common benchmark for long-term process control and monitoring performance evaluation. *Wat. Sci. Tech.*, **50**(11), 41–49.
- Spanjers, H., Vanrolleghem, P.A., Nguyen, K., Vanhooren, H. and Patry, G.G. (1998). Towards a simulation-benchmark for evaluating respirometry-based control strategies. *Wat. Sci. Tech.*, **37**(12), 219–226.
- Takács, I., Patry, G.G. and Nolasco, D. (1991). A dynamic model of the clarification thickening process. *Wat. Res.*, **25**(10), 1263–1271.
- Vanrolleghem, P.A., Rosen, C., Zaher, U., Copp, J.B., Benedetti, L., Ayasa, E. and Jeppsson, U. (2004). Continuity-based interfacing of models for wastewater systems described by Peterson matrices. *Wat. Sci. Tech.*, **52**(1–2), 493–500.