

## Systems analysis of urban wastewater systems – two systematic approaches to analyse a complex system

L. Benedetti\*, F. Blumensaat\*\*, G. Bönisch\*\*, G. Dirckx\*\*\*, N. Jardin\*\*\*\*, P. Krebs\*\* and P.A. Vanrolleghem\*

\*BIOMATH, Ghent University, Coupure Links 653, B-9000 Gent, Belgium

\*\*Institute for Urban Water Management, Dresden University of Technology, D-01062 Dresden, Germany

\*\*\*Aquaflin nv, Technology Department, Dijkstraat 8, B-2630 Aartselaar, Belgium

\*\*\*\*Ruhrverband Essen, Kronprinzenstraße 37, D-45128 Essen, Germany

**Abstract** This work was aimed at performing an analysis of the integrated urban wastewater system (catchment area, sewer, WWTP, receiving water). It focused on analysing the substance fluxes going through the system to identify critical pathways of pollution, as well as assessing the effectiveness of energy consumption and operational/capital costs. Two different approaches were adopted in the study to analyse urban wastewater systems of diverse characteristics. In the first approach a wide ranged analysis of a system at river basin scale is applied. The Nete river basin in Belgium, a tributary of the Schelde, was analysed through the 29 sewer catchments constituting the basin. In the second approach a more detailed methodology was developed to separately analyse two urban wastewater systems situated within the Ruhr basin (Germany) on a river stretch scale. The paper mainly focuses on the description of the method applied. Only the most important results are presented. The main outcomes of these studies are: the identification of stressors on the receiving water bodies, an extensive benchmarking of wastewater systems, and the evidence of the scale dependency of results in such studies.

**Keywords** Systems analysis; integrated urban wastewater management; substance flow analysis; WFD; benchmarking; scaling problem

### Introduction

The aim of this work was to perform a thorough and wide-focused systems analysis of the integrated urban wastewater system (catchment area, sewer, WWTP, river). The outcome of the study will ultimately serve as a basis for the development of a decision support aid that gives assistance for the cost-effective development of urban wastewater systems for Water Framework Directive (WFD) compliance. The research work reported in this paper is carried out within the scope of the EU project CD4WC which is supported by the European Commission under the 5th Framework Programme.

Among the wide suite of tools available to perform a systems analysis (Finnveden and Moberg 2001; Balkema *et al.* 2002) substance flow analysis (SFA) combined with mass balances proved to be appropriate tools to highlight pressures on the environment, i.e. on the receiving water, and to pinpoint information gaps (Belevi 2002; Jeppsson and Hellström 2002). The main limitation of SFA lies in the uncertainty usually associated to the data used, which are also of different nature and origin (Danus and Burström 2001). Using SFA as a tool for priority setting and follow-up is associated with considerable difficulties. However, it is still a useful tool for screening in order to identify areas for further and more detailed investigation. Similar studies can be found in (Lampert and Brunner 1999; Larsen 1999; Lindqvist-Östblom *et al.* 2001).

The evaluation of a list of indicators helped to characterise the behaviour of sewers and WWTPs in environmental and economic terms. A further objective was to recognize the information gaps in the system owed to the typical methods of data collection and

monitoring of the urban catchment. However, such results are not shown in this paper; only SFA and mass balances are discussed.

Two different approaches were adopted in the study to analyse different urban wastewater systems. Both imply a comprehensive collection of data and general information from wastewater operators, environmental agencies and authorities. In the first approach a wide ranged analysis of a system at river basin scale is applied. The Nete river basin in Belgium, a tributary of the Schelde, was analysed through the 29 sewer catchments constituting the basin. In the second approach a more detailed methodology was applied. Two urban wastewater systems with different characteristics (one system is characterised through urban and one through rural influence) situated within the Ruhr basin (Germany) were separately investigated on a river stretch scale.

Substances to be analysed for the study were water, BOD, COD, TN, TP and Zn: water was selected since the analysis of its flows can reveal problems such as in- and exfiltration, WWTP overload, hydraulic stress to receiving water body; BOD and COD are indicators of organic pollution with oxygen depletion and CO<sub>2</sub> emission; TN and TP reveal eutrophication potential in the receiving water; Zn is the most detectable heavy metal (therefore measurements are fairly reliable) and is representative of toxic contamination.

Within the wide set of components being part of the water cycle or interacting with it, only elements concerning the urban wastewater system were taken into account. Among this sub-set, the studied processes were the ones related to technical structures on which a water utility can act to improve the receiving water quality (sewer network, WWTP and receiving water body). For the processes included in this systems analysis all possible interactions were considered. The other compartments (households, industry, agriculture, atmosphere, groundwater, etc.) were assumed in this study as flux sources or sinks, so only the interactions with processes in the system were taken into account.

### **The Nete river basin**

The Nete river basin (1,673 km<sup>2</sup>, 595,823 inhabitants), located in the eastern part of Flanders (Belgium) was chosen for systems analysis since it is the basin with the best water quality and with the largest data set available in Flanders, due to specific studies regularly performed by VMM, the Flemish Environmental Agency (VMM 2001). The topography of the basin is definitively flat. The basin is characterised by the presence of extensive agriculture and farming, and scattered urbanisation with some small towns.

The basin is constituted by 29 sewer catchments. The wastewater system (WWTPs and main connectors of sewer networks) is operated by Aquafin, which was founded by the Flemish Government in 1990 as the licence holder for the sewage treatment infrastructure in Flanders. The small pipes of the sewer networks, from the households to the main connectors, are still managed by the municipalities.

### **Substance flows and mass balances – methodology**

Substance flows and mass balances were calculated for the whole year 2002. Measured water flows in the system were available for the WWTPs influents (daily), at the closing section of the river basin (hourly) and for the effluents of monitored industries (periodically). Water from households was estimated knowing the number of inhabitants and assigning a pro capite water use (VMM 2001). A fraction of the rainfall from atmosphere – the yearly rainfall in the basin was available, as average of 11 measurement stations – was assumed to end directly in the receiving water body; another fraction, function of the impervious area in the basin, was routed through the sewer system (stormwater); the remaining rainfall was considered as draining to the water table or partly evaporating.

Parasite water was calculated subtracting water flows from households and industries from the dry weather flow entering the WWTP. The dry weather flow for each day of the year is the moving average with a window of 21 days, and it expresses the flow without rainwater, with the assumption that at least one day on twenty-one is a dry day (Jardin 2003). The water flow discharged directly into the receiving water body (CSO) was calculated as the total stormwater entering the sewer network minus the amount of stormwater treated in WWTPs. The flow of treated stormwater is the total water flow entering WWTPs minus the dry weather flow (Jardin 2003). Pollutants loads from households were estimated from the number of inhabitants and from the assigned daily substance release (VMM 2001). Concerning TN and TP loads from agriculture, they are results of measures of manure production and modelling of nutrients release (VMM 2001). Pollutants loads from WWTPs and industries are calculated from water flow and pollutants concentrations measurements available approximately every 10 days.

**Results and discussion**

Figure 1 gives an example of substance flows by means of Sankey diagrams and bar charts. Bar charts show the flows in the diagrams with their possible minimum and maximum values according to the uncertainty associated to the data type (Danis and Burström

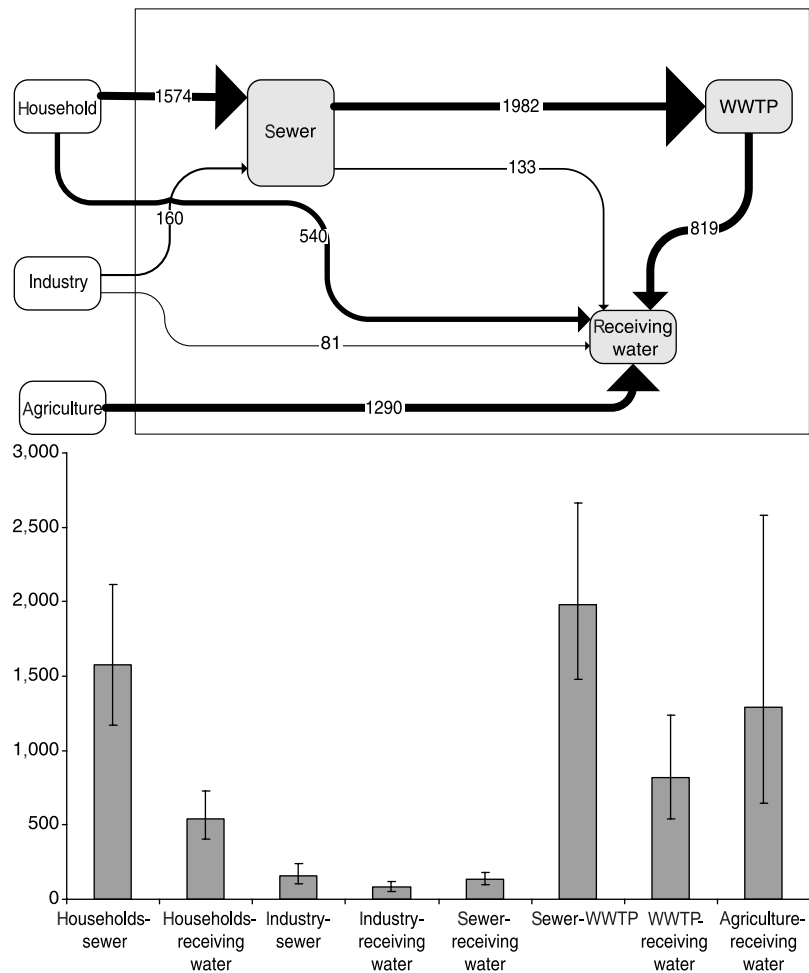

**Figure 1** Sankey diagram (top) and flows with uncertainty range (bottom); TN [ton/y] in the Nete basin

2001). Loads from households are estimated from the number of inhabitants and daily substance release (TN:  $10 \text{ g inh}^{-1} \text{ d}^{-1}$ ).

Gaps in mass balances were only calculated for the sewer network, with households and industry as inputs (rainfall and parasite water as well for the water balance) and WWTP and receiving water as outputs. Table 1 shows the gaps in the sewer mass balance for the whole Nete basin for the substances taken into account.

Combining the information obtained from flow calculations and from mass balances with information provided by Aquafin, the following conclusions can be drawn: *Water* – In the Nete basin the groundwater table is rather high (causing infiltration) and several ditches are connected to the sewer system, contributing to the loads of parasite water (44% of dry weather flow) and of pollutants, especially in rural areas. Furthermore, some CSO outlets are sometimes letting river water in the sewer system, for lack of flap valves and high water levels in river and ditches. *Pollutants* – With the assumption that BOD is partly degraded by biochemical processes in the sewer network, similar gaps in the mass balances can be noted in BOD and COD, while neglecting the loads brought by connected ditches brought a similar underestimation of the inputs of TN and TP. Concerning zinc, as evident in Table 1, the low detection limit causes a problem to flow analyses; the main zinc sewer inflow that is not taken into account is probably the zinc content of stormwater, of which only the contribution from roofs and gutters washing has been estimated in this study; this leads to a 138% gap in the zinc mass balance.

Concerning pressures directly impacting on the receiving water, Figure 2 shows substance loads discharged in the Nete relative to the total load. It appears that untreated households are the main stressor for acute oxygen depletion (BOD, 89% of load) for delayed oxygen demand (COD, 60%) and for eutrophication (TP, 45% and TN, 24%). Agriculture also has a relevant impact on eutrophication (TN, 44% and TP, 25%); it is to be noticed that no data were available on BOD and COD loads from agriculture. WWTPs contribute substantially to all loads but are in no case the main stressor; they are for zinc, but only apparently because of the fact that zinc originating from roofs and gutters is not measured in stormwater.

#### The scale of the study – a problem

The calculated water flows directly discharged into the receiving water body via CSOs (Figure 3) show a large variance. However, the average value of 4% (relative to the total stormwater entering the sewer) for the whole Nete basin is well in the range of percentages found in literature (Schlüter and Mark 2003). The same behaviour – i.e. large variance for individual basins, but average in agreement with literature – was found for sewer mass balances (not shown).

This underlines an important aspect in this type of studies: the spatial scale chosen. For large regions like a river basin, results are likely to fall in the narrow range of results found in similar studies, since several different contributions compensate each other, producing an average typical for a certain kind of large area. However, for small catchment areas with sewer catchments of small WWTPs, local boundary conditions and uncertainties play a major role and results vary to a large extent in seemingly similar areas.

**Table 1** Gaps in the sewer mass balance for the whole Nete basin; positive figures indicate outputs larger than inputs

Water	BOD	COD	TN	TP	Zn
6%	– 17%	– 3%	22%	25%	138%

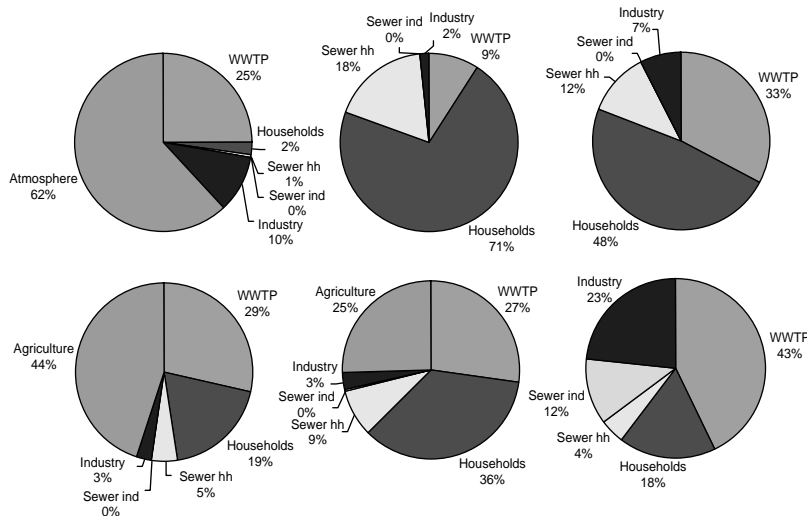

**Figure 2** Relative loads into the Nete river – from left to right and from up to down: water, BOD, COD, TN, TP and Zn; “sewer ind” and “sewer hh” indicate the loads discharged in the receiving water via the sewer network by industry and household respectively

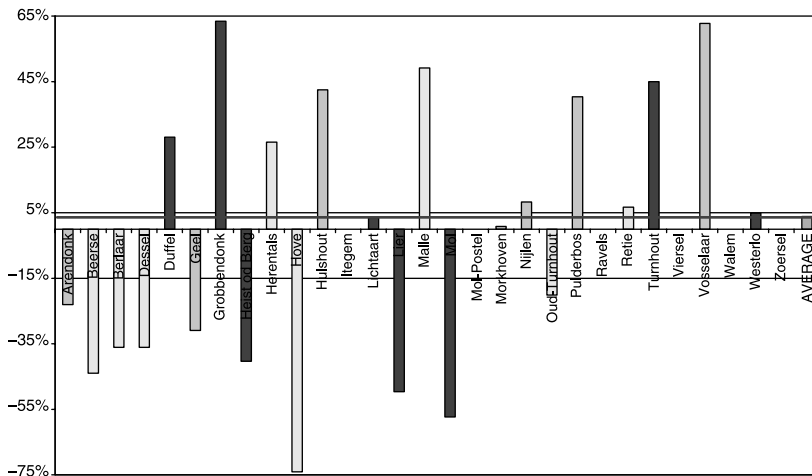

**Figure 3** Percentages of estimated CSOs (relative to the total stormwater entering the sewer) for the 29 Nete catchments; in medium grey are reliable data, in light grey less reliable data, in dark grey scarcely reliable data

### Ruhr river basin

This section describes a spatially more detailed approach to perform a systems analysis on an urban wastewater system. The methodology developed was applied to two relatively small catchments situated in Germany influenced by different system characteristics. In the study, sub-systems were not considered isolated but rather in relevance to each other to obtain understanding not only on the particular sub-systems, but also about interactions between them.

In the following, a rather simple method to analyse fluxes within the system is described. The concept aimed to reduce the effort spent on data analysis; assumptions and adequate estimations were applied to reduce investigational effort. This way, critical pathways in the entire system and influencing stressors on the environment, on the receiving

water in particular, were identified without conducting extensive investigations such as dynamic simulations.

**System simplification**

The actual catchment structure was simplified in order to facilitate the data collection and analysis procedure. The overall catchment was divided into sub-catchment areas that were each allocated to a particular CSO structure, i.e. stormwater treatment facility. Every single sub-catchment was considered as individual system with no interactions to other sub-systems. An overview of the simplified system structure is shown in Figure 6.

Zooming into the overall system structure reveals a closer look at one single sub-catchment area as shown in Figure 4. The figure shows one sub-catchment area allocated to the corresponding CSO structure including all flows that have been considered. The grey-lined structure shows an upstream located CSO structure ( $n - 1$ ) indicating the origin of the throttle flow  $Q_{th,n-1}$  as input into the CSO structure “downstream” ( $n$ ).

The following parameters were assumed constant for every sub-catchment area and CSO structure: population density; area (pervious/ impervious); rainfall duration; rainfall intensity; area connected to combined, i.e. separate sewer network; CSO storage capacity (in-sewer storage or storage volume of the retention tank); throttle flow ( $Q_{th}$ ).

However, parameters can vary depending on local boundary conditions for each sub-catchment area. For instance, different infiltration rates can be applied depending on present groundwater levels.

**Balancing flows - methodology**

No reliable data regarding CSO performance could be obtained during the data collection. Some information about measured water levels in very few CSO structures was available, but this information could not be used to estimate reliable CSO quantities. Incompleteness and uncertainty of these data sets would have given low quality results for the estimation of CSO quantities with low significance. For these reasons, a specific method was used to estimate overflow volumes. Based on assumptions, a flow balance was formed in

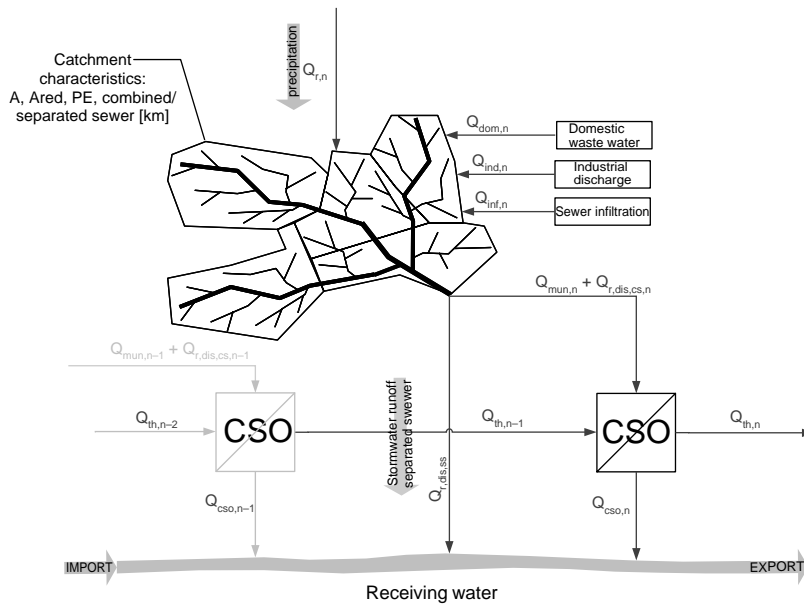

**Figure 4** Detailed view of a sub-catchment area including all flows considered

which CSO volumes discharged to the receiving water remained as the only unknown variable.

A water flow balance was formulated for each overflow structure as shown in Figure 4. The graph in Figure 5. illustrates the estimation of CSO volumes over the period of one year.

The estimation of CSO volumes is based on balancing the in- and output flows for each CSO structure. A stepwise subtraction of all losses in the catchment area (wetting losses), losses in the sewer network (unused sewer volume), retention volume of the CSO structure, and the throttle flow *minus* the municipal wastewater flow from the daily rainfall intensity, eventually provided the daily overflow volume. Ultimately, daily overflow volumes were summed up resulting in an annual overflow volume for the respective CSO structure.

Volumes calculated for throttle and wastewater flows are related to an average rainfall duration to guarantee unit consistency. The main assumptions made are: constant wetting losses; constant infiltration rates; no exfiltration; no stormwater retention in the catchment area; interpolated rainfall heights; evaporation has been neglected.

Considering the overall system, single CSO structures cannot be considered isolated. As already indicated in Figure 4, additional inflow from upstream located overflow structures must be taken into account when estimating the overflow volume for a CSO structure.

**Full-scale application**

The method outlined above was applied to two catchment areas situated in Western Germany.

*Catchment I* lies in a rural region, which is characterised by deep-cut river valleys and a hilly landscape. Developed urban areas are predominantly located in the valleys and at their flanks but few settlements are also situated on the heights. The urban development of the catchment is typical for a medium-sized German municipality: the degree of housing varies from high-density areas besides low-density areas. Settlements are almost completely connected to the municipal sewer system that is largely implemented as combined sewer system. Approximately 31,400 residents are connected to the sewer system; the population density is 22 PE/ha.

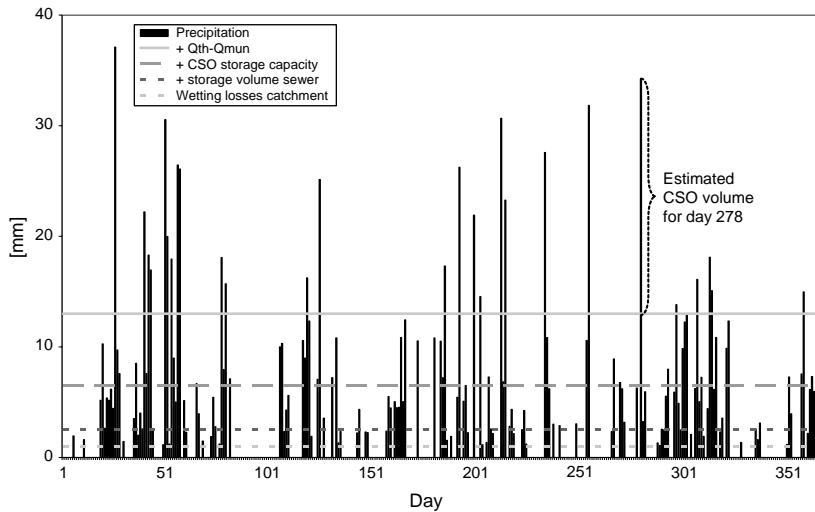

**Figure 5** Estimation of CSO volumes (daily rainfall heights minus retention and treatment capacity)

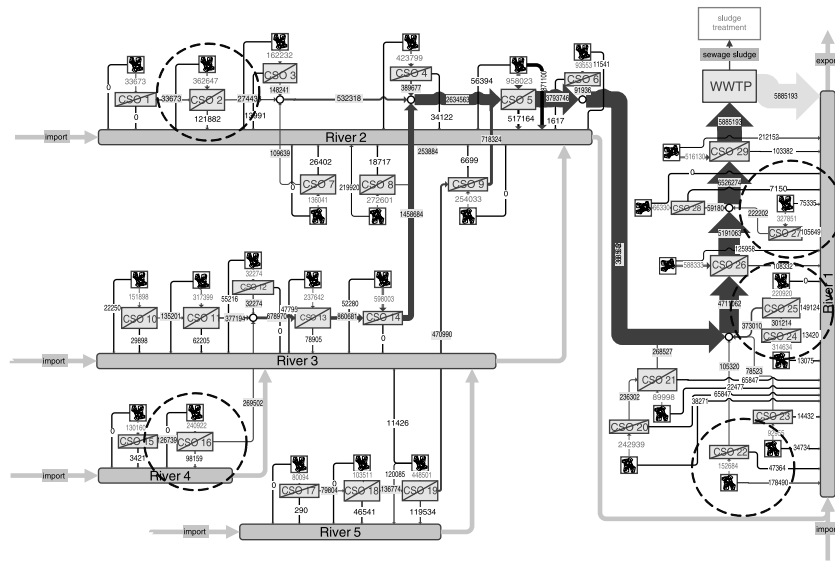

**Figure 6** Substance flow: water flow (in  $\text{m}^3/\text{a}$ ) for the wastewater system in catchment I

*Catchment II* lies in a highly developed urban and industrially influenced area. The urban development of the catchment is typical for a metropolitan German city: the degree of housing is high-density and settlements are completely connected to the municipal sewer system, largely implemented as combined sewer system. Approximately 186,000 inhabitants are connected to the sewer system and a WWTP; the population density is 41 PE/ha.

Exemplary for both case studies, the flow sheet in **Figure 6** shows water fluxes going through the system, whereas numbers in the flux lines indicate the estimated annual volume for each flux.

Illustrating annual flows in this way clearly reveals critical pathways in the system. In the given example, the dashed circles indicate critical points in which the absolute overflow volume that is discharged to the receiving water exceeds average values. Comparing the overflow volumes with the wastewater volumes discharged to the WWTP for the corresponding catchment area, the overall overflow related to the entire catchment is 0.31, whereas the specific overflow for the two critical points is 0.44 and 0.36 respectively.

The identification of such crucial emission points serves as a basis for a more detailed analysis. Further balances for key substances such as COD,  $\text{NH}_4\text{-N}$ , etc. will be estimated to evaluate pollution loads discharged in relation to the present base flows in the receiving water. Additionally, dynamic simulations are going to be performed to obtain a more detailed insight of effects during single events and to approve the estimated results. This will ultimately give systems operators valuable information which allow them to apply selected measures for the improvement of the overall system performance. As one beneficial aspect, costs for the system development and optimisation may be reduced.

## Conclusions

The main pressures on the Nete river are untreated households, especially for BOD and COD. For TN, agriculture is the main stressor. Concerning TP, all stressors taken into account (households, industries, WWTPs, agriculture) have a comparable importance.



It is very difficult to obtain reliable flows for heavy metals due to the low detection limit and to the fact that a large fraction comes from stormwater, for which there are usually no quality measurements.

Values of some indicators at catchment scale show a large variance (e.g. mass balances, CSOs) but the average value is well in the range of values found in literature. This is an important aspect of this kind of studies which depend on the geographic scale chosen. For large regions like a river basin, results are likely to fall in the range of results found in similar studies, but with small areas local factors play a major role.

A full-scale system including fluxes running through such system is described and illustrated; boundaries and interfaces are outlined. Water flow schemes are established and analysed for two pilot systems (receiving water flows excluded). Yearly overflow volumes from stormwater treatment facilities are quantified by applying a balancing method that was developed. Critical points in the system that thus could be identified will serve as indication for further, more detailed analysis.

### Acknowledgements

The results presented in this publication have been elaborated in the frame of the EU project CD4WC, contract no EVK1-CT-2002-00118. The programme is organised within the Energy, Environment and Sustainable Development Programme in the 5th Framework Programme for Science Research and Technological Development of the European Commission.

### References

- Balkema, A.J., Preisig, H.A., Otterpohl, R. and Lambert, F.J.D. (2002). Indicators for the sustainability assessment of wastewater treatment systems. *Urban Water*, **4**, 153–161.
- Belevi, H (2002). Material flow analysis as a strategic planning tool for regional waste water and solid waste management. [www.gtz.de/ecosan/download/belevi.pdf](http://www.gtz.de/ecosan/download/belevi.pdf).
- Danius, L. and Burström, F. (2001). Regional material flow analysis and data uncertainties: can the results be trusted? *Proceedings of 15th International Symposium on Informatics for Environmental Protection*, Zurich (Switzerland), 10–12 October 2001.
- Finnveden, G. and Moberg, Å. (2001). Environmental Accounts and Material Flow Analysis and other environmental system analysis tools. In *Proceedings of Workshop on Economic Growth, Material Flows and Environmental Pressure*, Stockholm (Sweden), April 2001.
- Jardin, N. (2003). Vereinheitlichung und Herleitung von Bemessungswerten für Abwasseranlagen (A 198). In *Proceedings of Regen- und Mischwasserbehandlung Seminar*, Würzburg, Technische Akademie Hannover, Germany, 23–24 September 2003.
- Jeppsson, U. and Hellström, D. (2002). Systems analysis for environmental assessment of urban water and wastewater systems. *Wat. Sci. Tech.*, **46**(6–7), 121–129.
- Lampert, C. and Brunner, P.H. (1999). Materials accounting as a policy tool for nutrient management in the Danube basin. *Wat. Sci. Tech.*, **40**(10), 43–49.
- Larsen, T.A. (1999). Nutrient cycles in urban water management. *EAWAG news*, **46**, 21–23.
- Lindqvist-Östblom, A., Sörme, L. and Söderberg, H. (2001). Substance flow analysis as a tool to support environmental management of heavy metals in wastewater treatment companies. In *Proceedings of Workshop on Economic Growth, Material Flows and Environmental Pressure*, Stockholm (Sweden), April 2001.
- Schlütter, F. and Mark, O. (2003). Dynamic modelling of pollutants from CSOs. *Wat. Sci. Tech.*, **47**(4), 149–156.
- VMM (2001). *General Water Quality Plan 2 - 10.Nete*, Flemish Environment Agency, Belgium.